



STROBECOM II

## DETOC22-IC-X

2-Head, 2- Direction, 2-Channel, 2-LED, Standard Detector with Integrated Confirmation and TOMAR OSPOC Automatic Test



- INTEGRATED CONFIRMATION technology provides low-cost, easily installed visual feedback of preemption to vehicle drivers and citizens.
- Tool-less swivel of detector head makes aiming easy
- Five colors of LED confirmation light available (Amber, Blue, Green, Red, and White)
- Sensor technology for sunlight rejection unmatched by any other system
- Fully encapsulated electronics for complete resistance to water, heat, and vibration
- Protected from mis-wiring and electrical transients
- Simple advance detector installation for detection around corners and over hills

TOMAR's DETOC22-IC-X Strobecom II dual direction preemption detector with automatic detector test and Integrated Confirmation includes two detector heads, two output channels, and two LED confirmation lights.

The DETOC22-IC-X senses the optical pulses emitted by properly equipped emergency & transit vehicles. Mounted to observe an approach to an intersection, the DETOC22-IC-X is used with TOMAR OSPOCV2 optical signal processors to inform the traffic control system and provide visual confirmation of the presence of designated vehicles that may affect normal traffic signal behavior.

TOMAR's Integrated Confirmation technology (US patent 8,742,946) allows powering and operation of the built-in LED confirmation light using only the standard preemption detector cable. No additional mounting, power source, programming, or wiring is required.

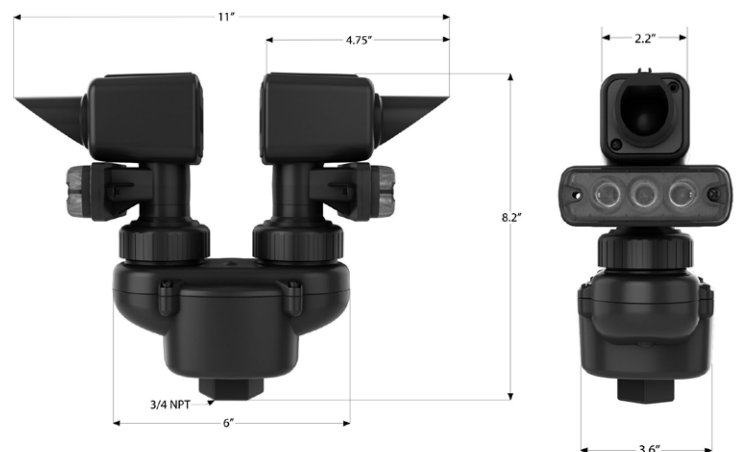



**Specifications**

Item	Description
Maximum Detection Range	2500 feet minimum when used with 4000 series optical signal processor in clear atmospheric conditions
Maximum Cable Length	Up to 600 feet of TOMAR M913 preemption cable between optical signal processor and DETOC22-IC-X
Field of View	13 degrees conical centered around viewport normal axis (typical)
Cable Type	TOMAR model M913 preemption detector cable
Operating Temperature	-40 to +75 degrees C
Physical Construction	The DETOC22-IC-X enclosure is black, glass filled, UV stabilized polyamide suitable for all weather use. All electronics circuitry is completely encapsulated in polyurethane for protection from shock, vibration, and moisture.
Mounting	The DETOC22-IC-X is easily mounted using standard hardware on either span wire or mast arm. The unit has a 3/4" female pipe mount hub and internal terminal block for connection to a 3/C shielded detector cable (TOMAR M913)

**Ordering Info**

Catalog Number	Description
DETOC22-IC-X	Two head, two direction, two channel, two LED optical signal detector with automatic test (x = confirmation light color A, B, G, R, or W)

**TRUE 10 YEAR WARRANTY!**

10 year warranty covers the DETOC Series and all STROBECOM II components. Unlike other manufacturers, TOMAR's ten year warranty has NO fees or charges for warranty repairs after five years.

NOTICE: The sale of these items are restricted to state and local governments and to be authorized distributors only.